

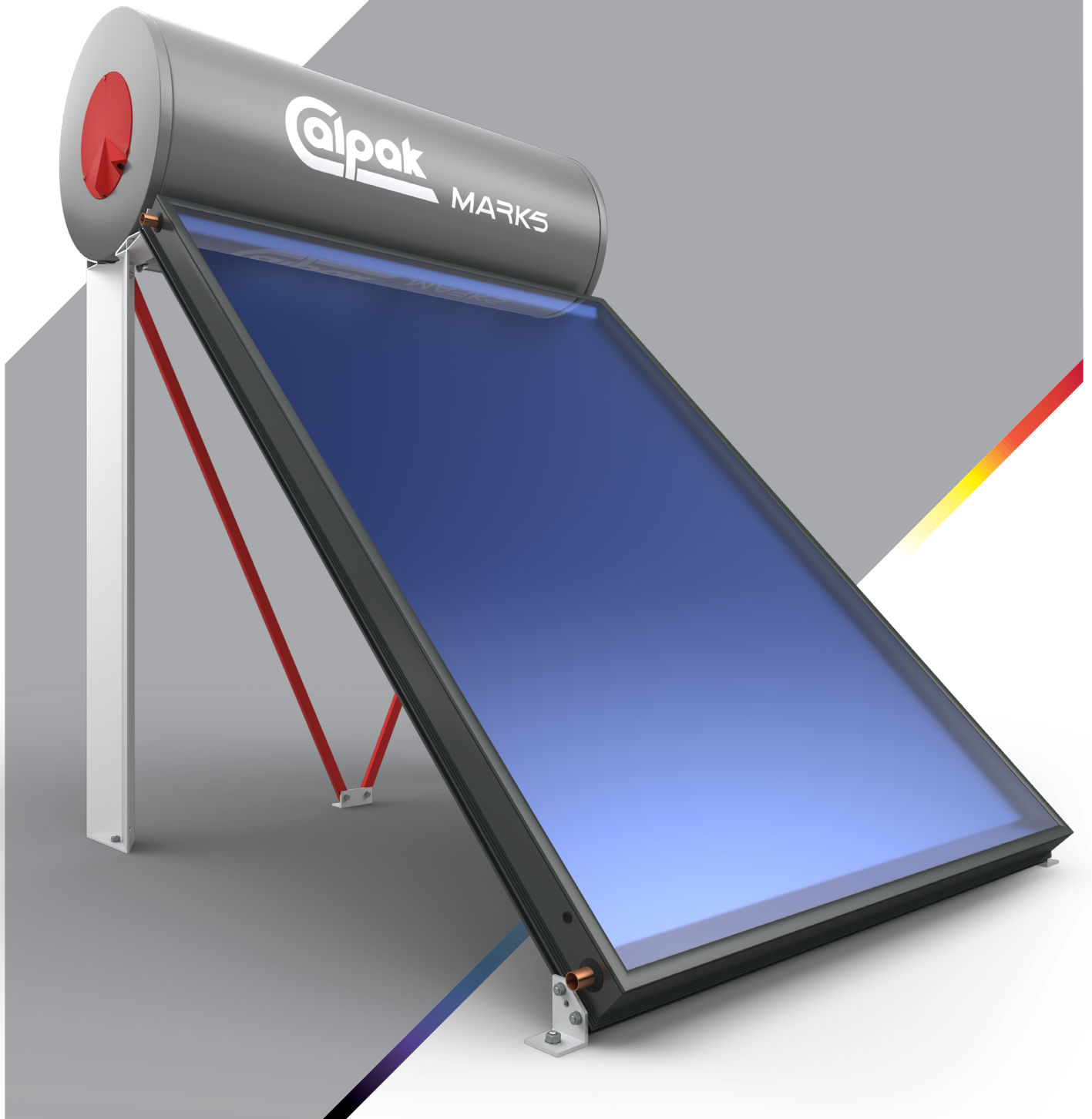

MARK5

POWER  
ROBUSTNESS  
DESIGN



# MARK5

## POWER

A solar water heater must be very powerful to fully meet your hot water needs.

Mark5, based on certified tests, has one of the most powerful collectors in Europe (80% efficiency and minimal thermal losses), as well as a well designed heat exchanger that ensures efficient energy transfer from the collector to the tank.



## ROBUSTNESS

It must also be robust so that you can enjoy free solar energy for as many years as possible.

Mark5 is made with the best materials, following the strictest quality standards. The tank is made of DC-03 steel according to DIN 10130, it is robotic welded with pulse tig technology and enameled according to DIN 4753/3. The collector's frame is made of a 2.4 mm double-wall aluminum profile and has an aluminum back. The flat roof support is also made entirely out of aluminum.

## DESIGN

Finally, it must be well designed to match your aesthetics.

Mark5 is designed according to modern abstraction & ergonomics trends and has an honorary reference in the internationally recognized reddot directory.



## HIGH TECHNOLOGY PRODUCTION

Mark5 is entirely produced in the new **smart factory** of Calpak that has been recognized as the most advanced in Greece in terms of **robotic technology** and **artificial intelligence** application that make possible the automatic optimization of mechanical processes.



## TANK MARK5

- 1. Inner cylinder according to DIN 10130 & direct enamelling according to DIN 4753/3
  - › Durability over time
  - › Clean water
- 2. All weldings are made with robotic pulse tig technology
  - › Durability over time
  - › Quality guaranteed
- 3. Thermodynamically designed closed circuit & special diffuser
  - › Hot water even faster
- 4. Insulation made of dense ecological polyurethane with a thickness of 50mm
  - › Hot water in the next morning

## COLLECTOR M5

- 5. Double-wall aluminum profile, 2.4mm thick
  - › Durability over time
  - › More hot water
- 6. Absorber with 12 copper pipes & highly-selective Tinox surface 0.5mm
  - › More hot water
- 7. Low-Iron tempered glass with high transmittance (T> 91.5%)
  - › More hot water
- 8. Compressed structure & aluminium back
  - › Durability over time
  - › Neat looks

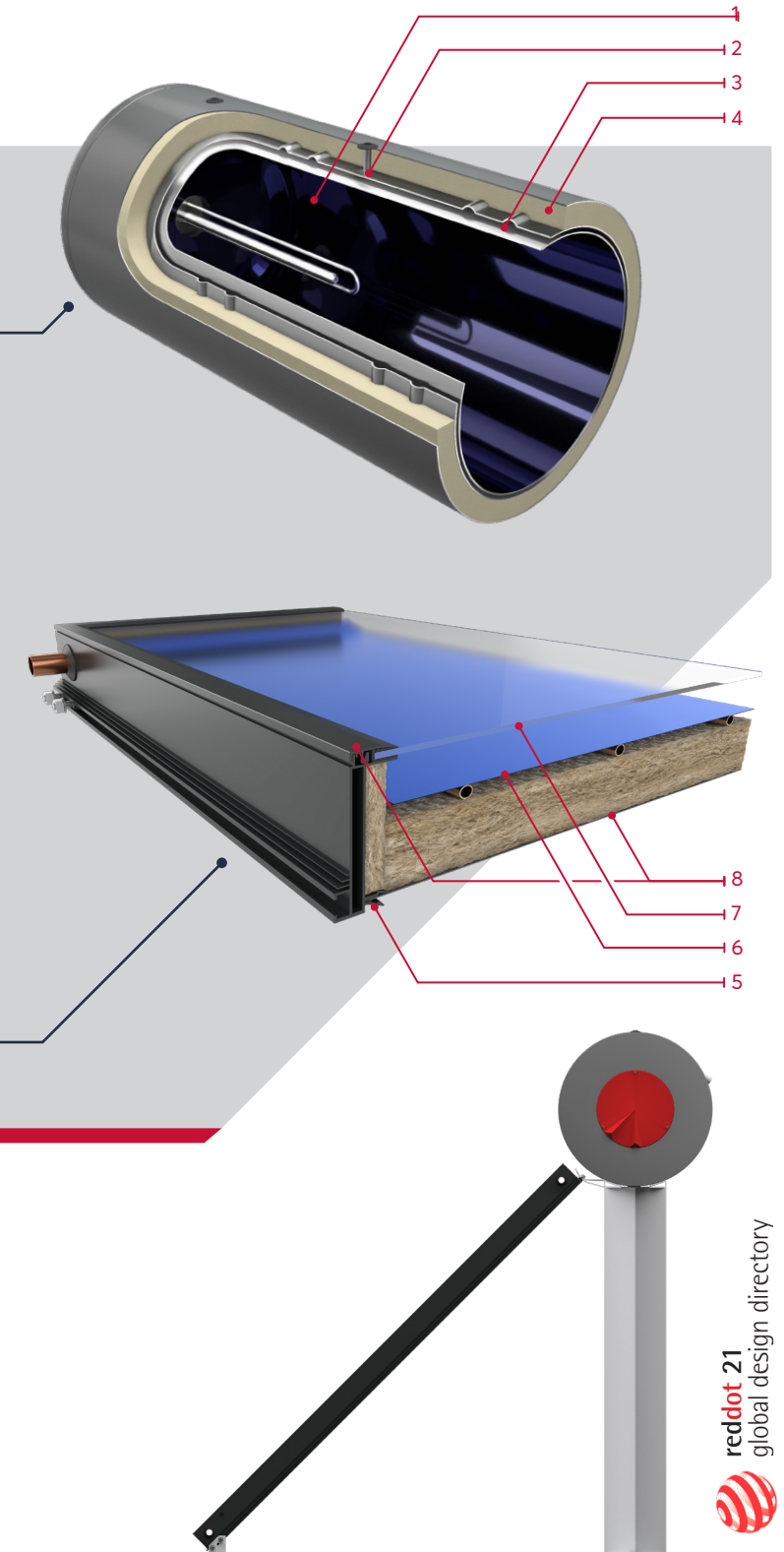

# MARK5

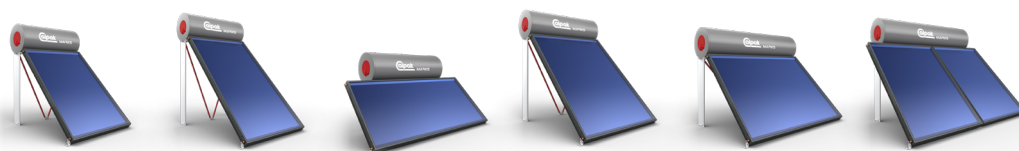

	160/2,1	160/2,6	200/2,6H	200/3	300/3H	300/4,2
Number of persons	3-4	4-5	4-5	5-6	6-7	7-8

## COLLECTOR

Gross area	2,09 m <sup>2</sup>	2,60 m <sup>2</sup>	2,60 m <sup>2</sup>	3,00 m <sup>2</sup>	3,00 m <sup>2</sup>	4,18 m <sup>2</sup>
Absorber's copper risers	12	12	18	15	15	24
Absorber surface treatment	high selective (Tinox) 0,5mm (a > 95% , e < 3,5%)					
Absorber welding	laser					
Casing material	2.4mm double-wall aluminum profile					
Glass	tempered glass 3.2mm , low-iron (transparency>91,5%)					
Insulation	rock wool with density 50 kg/m <sup>3</sup> and thickness 40mm					
Collector production method	Compressed glass, aluminium frame and back					
Optical efficiency	$\eta_0 = 79,5\%$	$\eta_0 = 79,5\%$	$\eta_0 = 79,5\%$	$\eta_0 = 80\%$	$\eta_0 = 80\%$	$\eta_0 = 79,5\%$
Thermal loss coefficient	$\alpha_1 = 3,75$	$\alpha_1 = 3,75$	$\alpha_1 = 3,75$	$\alpha_1 = 3,27$	$\alpha_1 = 3,27$	$\alpha_1 = 3,75$
Annual output power (Athens 50°C)	1867 kWh	2323 kWh	2323 kWh	2792 kWh	2792 kWh	3734 kWh
Annual output power (Würzburg 50°C)	1026 kWh	1277 kWh	1277 kWh	1552 kWh	1552 kWh	2052 kWh
Certifications	Solar-Keymark, DCL					

## TANK

Volume	151 lt	151 lt	192 lt	192 lt	295 lt	295 lt
Inner tank design	By Interdomo (with deep side cups and internal welding that ensure perfect enameling)					
Tank / jacket heat exchanger material	DC-03 2,5mm steel / DC-03 1,5mm steel (DIN 10130)					
Welding method / Quality control	Robotized pulse tig with double quality control (before and after enameling) at 15 bar					
Corrosion protection	Direct enameling in accordance to DIN 4753/3, raw material from Wendel					
Cathodic protection	Magnesium bar (DIN 4753/6)					
Anti-freezing protection	Anti-freezing & anti-corrosive Calpak fluid (propylene glycol)					
Insulation	Injected PU foam without CFC (43 kg/m <sup>3</sup> density and 50mm thickness)					
Accessories included	Inox flange with electric immersion heater 3,5 Kw, safety and non-return valve, venting valve					
Connecting pipes	Insulated inox flexible pipes 316L, 21mm (threads of 3/4" at 30° inclination for optimal jet)					
Connection with diesel / gas burner	With an additional integrated heat exchanger (Trien models)					
Flat / inclined roof support material	Aluminium / galvanised steel					
Certifications	Solar-Keymark, email (enamel quality mark), ROHS (hygienic DHW), CE					

## DIMENSIONS

Installation at 45° (Height, Width, Length - mm)	1700, 1684, 1230	1989, 1973, 1230	1370, 1324, 2107	1904, 1867, 1525	1552, 1515, 2310	1700, 1684, 2553
Installation at 30° (Height, Width, Length - mm)	1326, 1892, 1230	1531, 2247, 1230	1093, 1488, 2107	1476, 2152, 1525	1228, 1772, 2310	1326, 1892, 2553

Quality Marks:



Laboratories:



Certification bodies:



Industry Federations:

